

负温度系数（NTC）热敏电阻器：

■ 特点

- 1、产品体积小，本体尺寸 $\Phi 5\text{mm} \sim \Phi 30\text{mm}$
- 2、功率大，抑制浪涌能力强，反应速度快
- 3、寿命长，可靠性高
- 4、系列全，应用范围宽
- 5、高额定功率
- 6、工作温度范围宽： $-40 \sim +200^{\circ}\text{C}$

■ 应用范围

- 1、开关电源，转换电源，UPS 电源
- 2、电子节能灯，白炽灯，其它照明灯
- 3、变压器，适配器
- 4、各类显像管，显示器

■ 产品标识说明

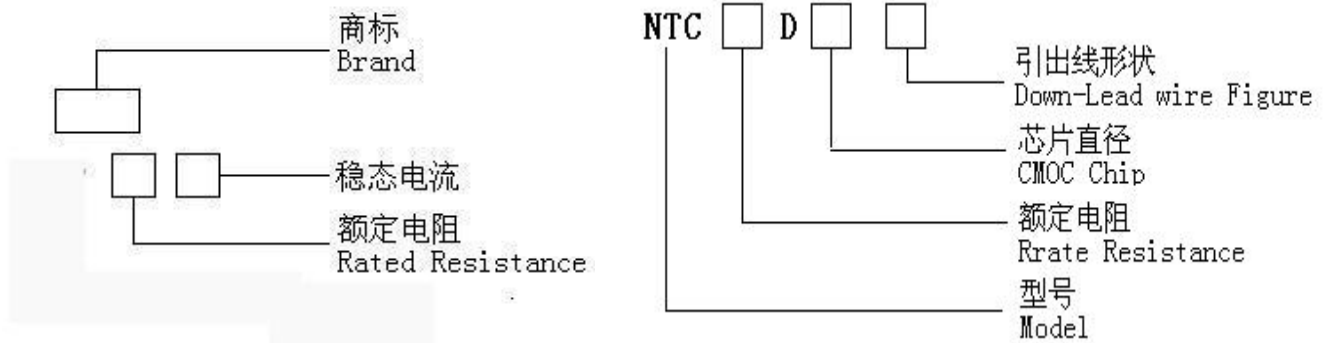

■ 外型尺寸

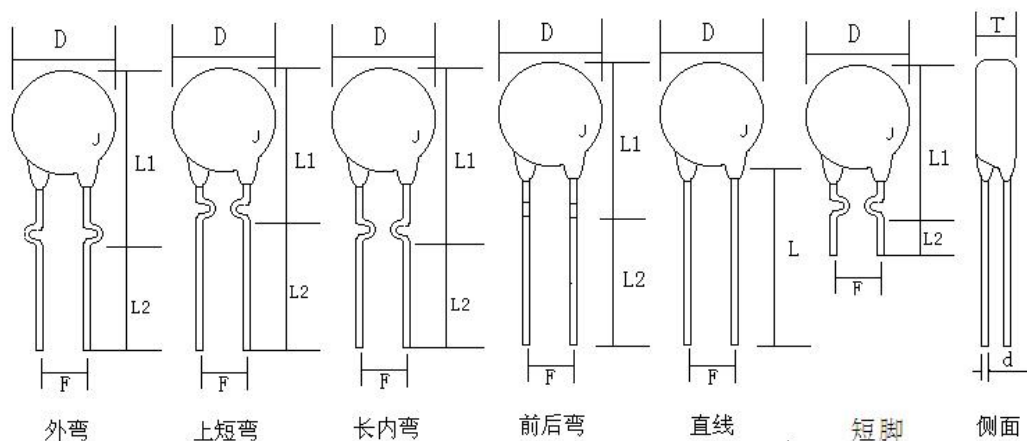

■ 尺寸参数

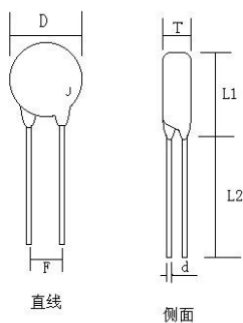

银片尺寸	Dmax(成品)	F±1.0	T Max	LMin	d±0.06
Φ5	6.0	2.5/5.0	5.0	25.0	0.45/0.6
Φ7	8.0	5.0	5.0	25.0	0.6/0.8
Φ8	10.0	5.0/7.5	5.0	25.0	0.6/0.8
Φ10	12.0	5.0/7.5	5.0	25.0	0.6/0.8
Φ13	14.0	7.5	5.5	25.0	0.8
Φ15	16.0	7.5	5.5	25.0	0.8
Φ20	22.0	7.5/10	6.5	20.0	1.0
Φ25	26.0	10.0	6.5	20.0	1.0
Φ30	32.0	10.0	6.5	20.0	1.0

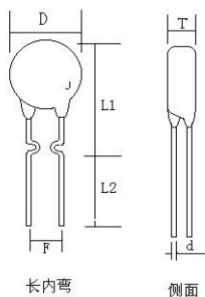

银片尺寸	Dmax(成品)	F±1.0	T Max	L1Max	L2Min	d±0.06
Φ7	8	5	5	16	20	0.6/0.8
Φ9	10	5.0/7.5	5	19	20	0.6/0.8
Φ11	12	5.0/7.5	5	20	20	0.6/0.8
Φ13	14	7.5	5.5	22	20	0.8
Φ15	16	7.5	5.5	24	20	0.8
Φ20	22	7.5/10	6.5	26	18	1.0
Φ25	26	10	6.5	32	16	1.0
Φ30	32	10	6.5	32	16	1.0

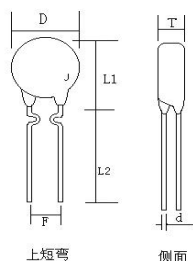

银片尺寸	Dmax (成品)	F±1.0	T Max	L1Max	L2Min	d±0.06
Φ5	6	2.5/5.0	5	10	20	0.45/0.6
Φ7	8	5	5	11	20	0.6/0.8
Φ9	10	5.0/7.5	5	15	20	0.6/0.8
Φ11	12	5.0/7.5	5	17	20	0.6/0.8
Φ13	14	7.5	5.5	19	20	0.8
Φ15	16	7.5	5.5	20	20	0.8

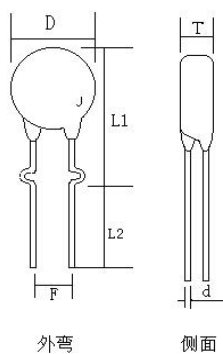

银片尺寸	Dmax (成品)	F±1.0	T Max	L1Max	L2Min	d±0.06
Φ5	6	2.5/5.0	5	9	20	0.45/0.6
Φ7	8	5.0	5	15	20	0.6/0.8
Φ9	10	5.0/7.5	5	16	20	0.6/0.8
Φ11	12	5.0/7.5	5	18	20	0.6/0.8
Φ13	14	7.5	5.5	19	20	0.8
Φ15	16	7.5	5.5	22	20	0.8
Φ20	22	7.5/10	6.5	28	20	1.0
Φ25	26	10	6.5	35	20	1.0
Φ30	32	10	6.5	39	20	1.0

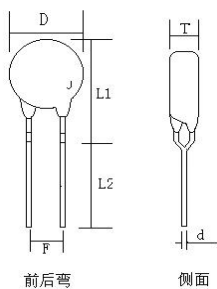

银片尺寸	Dmax (成品)	F±1.0	T Max	L1Max	L2Min	d±0.06
Φ7	8	5	5	12	20	0.6/0.8
Φ9	10	5.0/7.5	5	13	20	0.6/0.8
Φ11	12	5.0/7.5	5	16	20	0.6/0.8
Φ13	14	7.5	5.5	18	20	0.8
Φ15	16	7.5	5.5	21	20	0.8

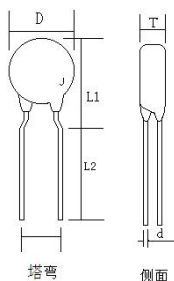

银片尺寸	Dmax (成品)	F±1.0	T Max	L1Max	L2Min	d±0.06
Φ5	6	2.5/5.0	5	8.5	20	0.45/0.6

■ 电性参数

产品型号	内部型号	额定电阻	最大稳态电流	残余电阻	耗散功率	时间常数	电容量
		(Ω)	(A)	(Ω)	(mW/ $^{\circ}$ C)	(S)	(μ F)
NTC5D-5	YFT051	5	1	0.318	7	18	100
NTC10D-5	YFT10X7	10	0.7	0.694	7	18	68
NTC4D-9	YFT043	4	3	0.171	15	28	330
NTC5D-9	YFT053	5	3	0.189	15	29	330
NTC6D-9	YFT062	6	2	0.194	15	28	220
NTC8D-9	YFT082	8	2	0.360	15	30	220
NTC10D-9	YFT102	10	2	0.412	15	30	220
NTC15D-9	YFT151	15	1	0.587	15	30	100
NTC20D-9	YFT201	20	1	0.724	15	30	100
NTC30D-9	YFT301	30	1	0.920	15	31	100
NTC2.5D-11	YFT2R55	2.5	5	0.086	17	43	570
NTC3D-11	YFT035	3	5	0.900	17	44	570
NTC4D-11	YFT044	4	4	0.135	17	44	470
NTC5D-11	YFT054	5	4	0.140	17	44	470
NTC8D-11	YFT083	8	3	0.230	17	45	330
NTC10D-11	YFT103	10	3	0.248	17	45	330
NTC12D-11	YFT122	12	2	0.416	18	45	220
NTC15D-11	YFT152	15	2	0.423	18	46	220
NTC16D-11	YFT162	16	2	0.423	18	46	220
NTC20D-11	YFT202	20	2	0.461	18	46	220
NTC22D-11	YFT222	22	2	0.507	19	46	220
NTC30D-11	YFT301X	30	1.5	0.600	19	46	150
NTC50D-11	YFT501X	50	1.0	0.919	19	47	100
NTC80D-11	YFT801X	80	1.0	1.490	19	47	100
NTC1.3D-13	YFT1R37	1.3	7	0.056	18	60	740
NTC1.5D-13	YFT1R57	1.5	7	0.066	18	62	740
NTC2.5D-13	YFT2R56	2.5	6	0.079	18	62	680
NTC4D-13	YFT045	4	5	0.108	19	63	570
NTC5D-13	YFT055	5	5	0.113	19	64	570
NTC7D-13	YFT074	7	4	0.169	19	62	470
NTC8D-13	YFT084	8	4	0.175	19	62	470
NTC10D-13	YFT104	10	4	0.185	19	62	470
NTC12D-13	YFT123	12	3	0.285	20	63	330



江苏宇飞特电子科技有限公司

NTC15D-13	YFT153	15	3	0.303	20	63	330
NTC16D-13	YFT163	16	3	0.304	20	62	330
NTC20D-13	YFT203	20	3	0.335	20	62	330
NTC1.3D-15	YFT1R38	1.3	8	0.043	21	76	820
NTC1.5D-15	YFT1R58	1.5	8	0.067	25	76	820
NTC2.5D-15	YFT2R58	2.5	8	0.680	25	80	820
NTC3D-15	YFT037	3	7	0.680	25	80	740
NTC5D-15	YFT056	5	6	0.101	25	81	680
NTC6D-15	YFT065	6	5	0.140	25	82	570
NTC7D-15	YFT075	7	5	0.156	25	82	570
NTC8D-15	YFT085	8	5	0.160	25	80	570
NTC10D-15	YFT105	10	5	0.162	25	78	570
NTC12D-15	YFT124	12	4	0.225	25	75	470
NTC15D-15	YFT154	15	4	0.234	25	83	470
NTC16D-15	YFT164	16	4	0.248	25	84	470
NTC20D-15	YFT204	20	4	0.259	25	83	470
NTC30D-15	YFT303X	30	3.5	0.394	25	83	330
NTC47D-15	YFT473	47	3	0.612	25	84	330
NTC120D-15	YFT1202X	120	2.5	1.482	25	85	220
NTC0.7D-20	YFT0R712	0.7	12	0.016	31	85	2200
NTC1.5-20	YFT1R59	1.5	9	0.033	31	99	1100
NTC3D-20	YFT038	3	8	0.049	31	102	860
NTC5D-20	YFT057	5	7	0.078	31	103	740
NTC6D-20	YFT066	6	6	0.102	31	100	680
NTC8D-20	YFT086	8	6	0.128	31	97	680
NTC10D-20	YFT106	10	6	0.146	30	97	680
NTC12D-20	YFT125	12	5	0.176	30	98	570
NTC16D-20	YFT165	16	5	0.191	30	98	570
NTC1D-25	YFT1R013	1	13	0.013	36	124	3300
NTC1.5D-25	YFT1R510	1.5	10	0.024	36	124	1100
NTC2.5D-25	YFT2R59	2.5	9	0.039	38	124	1100
NTC3D-25	YFT039	3	9	0.039	38	124	1100
NTC5D-25	YFT058	5	8	0.063	38	123	860
NTC8D-25	YFT087	8	7	0.103	38	123	740
NTC10D-25	YFT107	10	7	0.117	38	124	740
NTC12D-25	YFT126	12	6	0.140	38	125	680
NTC15D-25	YFT156	15	6	0.044	40	125	680
NTC1D-30	YFT0130	1	30	0.013	36	124	4700
NTC2D-30	YFT0223	2	23	0.039	38	124	3300

产品应用区域推荐：1、功率型直径 5mm 产品多应用于手机充电器领域；2、功率型直径 7、9、11mm 产品多应用于电动车充电器、开关电源、适配器、照明灯、白家电显示器等；3、功率型直径 13、15mm 产品多应用于液晶户外显示屏上的开关电源等；4、功率型直径 20mm 及以上片径的产品多应用于 UPS 电源等！